

# Sấy vật liệu

## ■ Các loại thiết bị sấy



1/15/2008

<http://environment-safety.com>

1

## Thiết bị sấy khay (mâm)

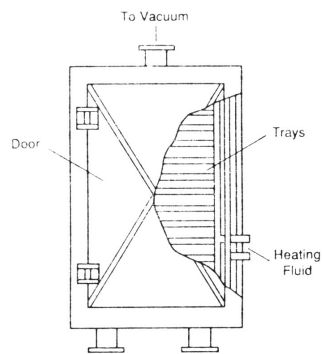

Figure 11.2-1. A tray dryer. Units like this are simple, flexible, and common, but can imply high labor costs (After King and Clark, *AIChE Symposium Series 205*, 1977).

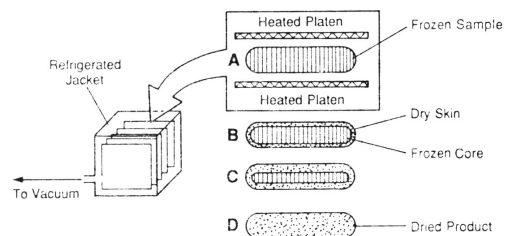
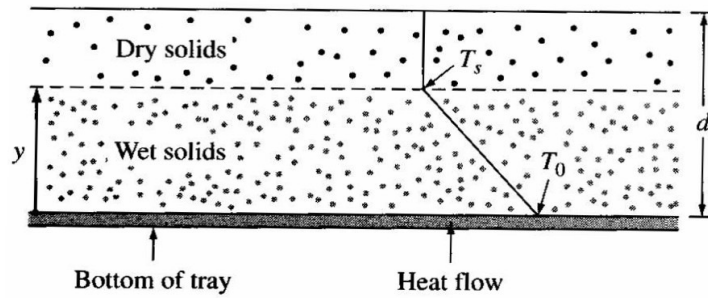

Figure 11.2-2. A freeze dryer. This type of equipment, which is often used for food, dries the solid via the sequence A → D shown on the right (After King and Clark, *ibid.*)

1/15/2008

## Sơ đồ quá trình sấy



### ■ Thiết bị sấy khay

3

## Thiết bị sấy chân không

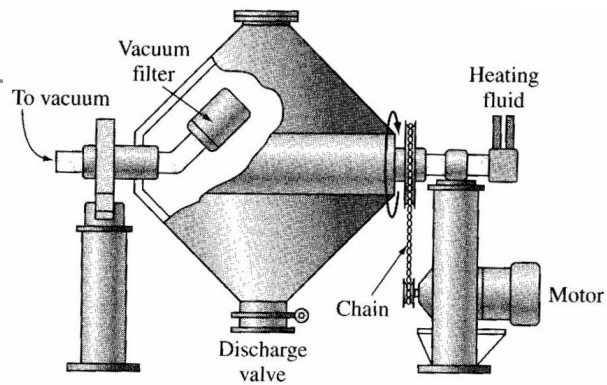

### ■ Thiết bị sấy chân không dạng thùng quay – batch vacuum rotation dryer

1/15/2008

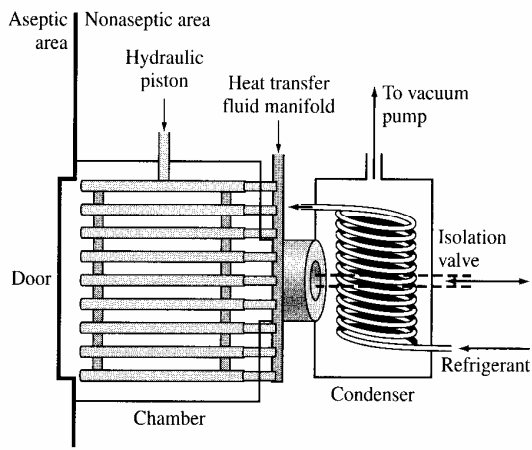
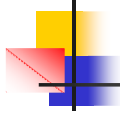

**Figure 10.7** Pharmaceutical freeze dryer.

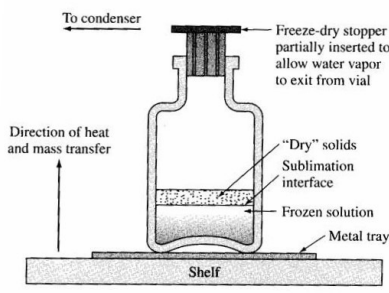

## Thiết bị sấy phun – Spray dryer

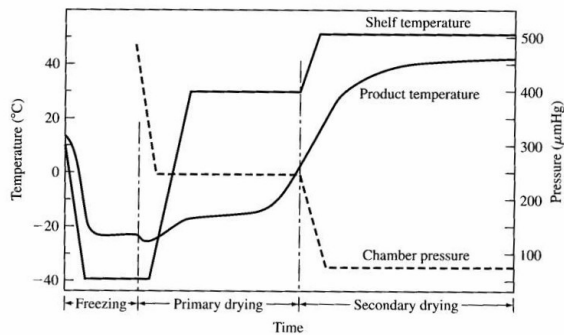

**Figure 10.9** Process variables during the freeze-drying cycle.

